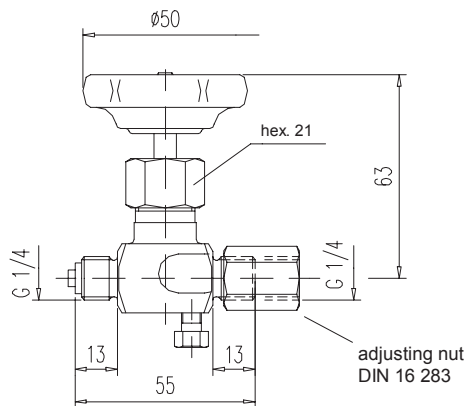
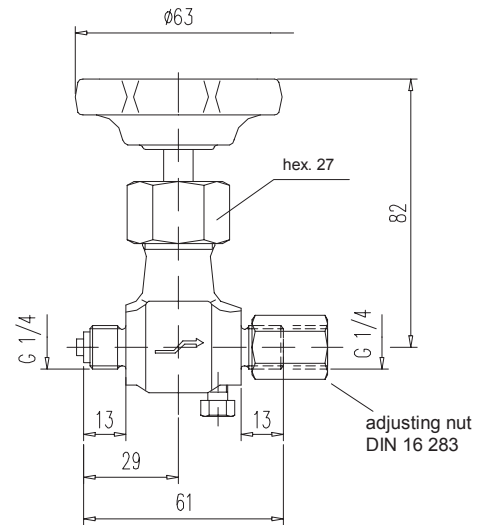
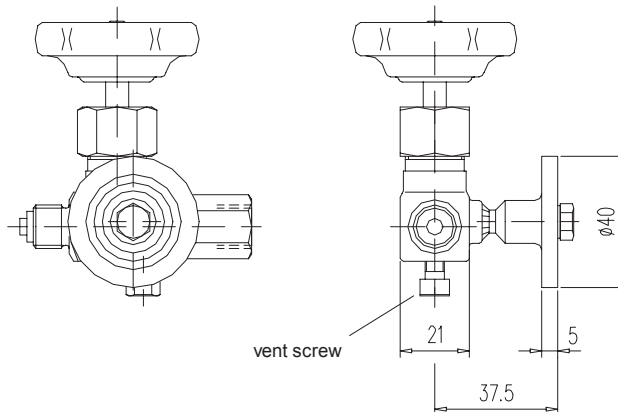

**Type 1**

**Type 2**

**Type 3**

**MOUNTING ACCESSORIES see section 10**

PN	Type	Material	Temperature rating	Part no.
125	1	brass	- 10 up to + 120°C	S004.12.000
250	2	steel st. st.	- 10 up to + 120°C - 20 up to + 200°C	S004.13.130 S004.13.230
125	3	brass	- 10 up to + 120°C	S004.12.065

Components	Brass <sup>1)</sup>	Steel	Stainless steel <sup>1)</sup>
	DIN - Material Number		
Body <sup>2)</sup>	brass	1.0460	1.4571
Valve stem	brass	1.4104	1.4571
Needle tip	brass	1.4104	1.4571
Packing	PTFE		
Union nut	brass	steel	stainless steel
Adjusting nut	brass	steel	stainless steel
Vent screw	1.4571		
Handwheel	plastic		

- **Body:** brass: pressed part  
steel / stainless steel: die-pressed part

- **Surface:** steel phosphatized

- Internal stem thread

1) Can also be supplied for oxygen service.  
Please notice order instruction B 3!

2) Available with inspection certificate 3.1  
acc. to EN 10 204