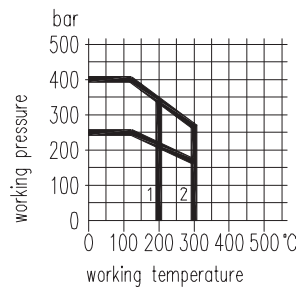
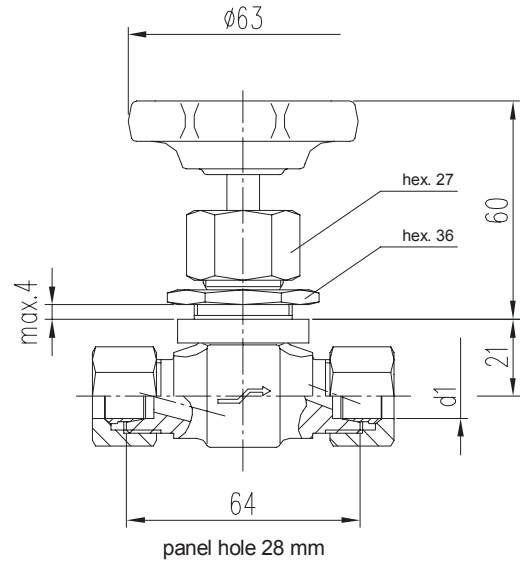
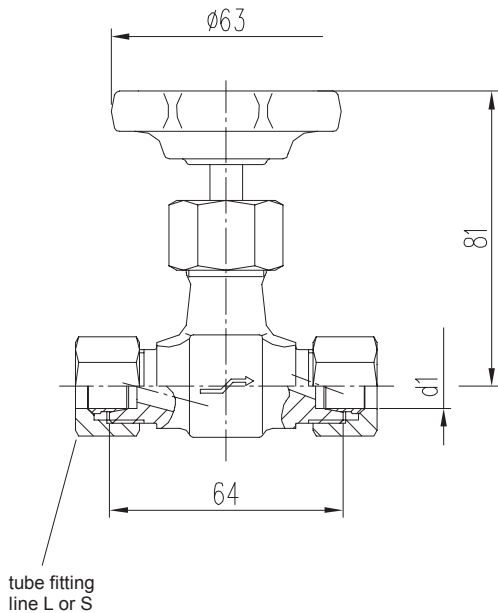

**ON REQUEST  
valve for panel mounting**

1 PTFE packing  
2 graphite packing

Tube O. D. d 1 [mm]	Material	Line L PN 250 Part no.	Line S PN 400 Part no.
6	steel st. st.	S338.03.180 S338.03.280	S338.03.130 S338.03.230
8	steel st. st.	S338.03.170 S338.03.270	S338.03.120 S338.03.220
10	steel st. st.	S338.03.160 S338.03.260	S338.03.110 S338.03.210
12	steel st. st.	S338.03.150 S338.03.250	S338.03.100 S338.03.200

Components	Steel	Stainless steel <sup>1)</sup>
	DIN - Material Number	
Body <sup>2)</sup>	1.0460	1.4571
Valve stem	1.4104	1.4571
Needle tip	1.4122 <sup>4)</sup>	1.4571
Packing	PTFE up to 200°C (graphite up to 300°C)	
Union nut	steel	1.4571
Handwheel	plastic <sup>3)</sup>	

- Body: die-pressed part
- Surface: steel phosphatized
- Internal stem thread
- Stem with cold rolled surface and non-rotating needle tip
- Special types are available

- 1) Can also be supplied for oxygen service. Please notice order instruction B 3!
- 2) Available with inspection certificate 3.1 acc. to EN 10 204
- 3) Can also be supplied with handwheel made of steel
- 4) 1.4122 quenched and tempered